



→ Cantilever lift for light commercial vehicles

DH-LM.10 • 500 - 1000 kg



The **4-cylinder** DH-LM.10 is DHOLLANDIA's **best seller** in the light capacity lift range. Thanks to its **superior stability** and performance in comparison to competing 2-cylinder lifts, and its competitive pricing, it offers an **excellent price-quality ratio**.

It is ideal for general purpose work and distribution transport up to 1000 kg useful capacity. It suits commercial vans and light trucks up to 7.5T GVW, but can also be mounted to small trailers and semi-trailers.

Lift capacity

CAP	CG	LM
500 kg	500 mm	2.5 kNm
750 kg	600 mm	4.5 kNm
1000 kg	600 mm	6 kNm

Weights [see pg. 11]

ALU platform	
1250 mm	205 kg
1450 mm	213 kg
1600 mm	219 kg
1800 mm	229 kg

Weights incl. CE bumper

Best seller: superior stability and performance

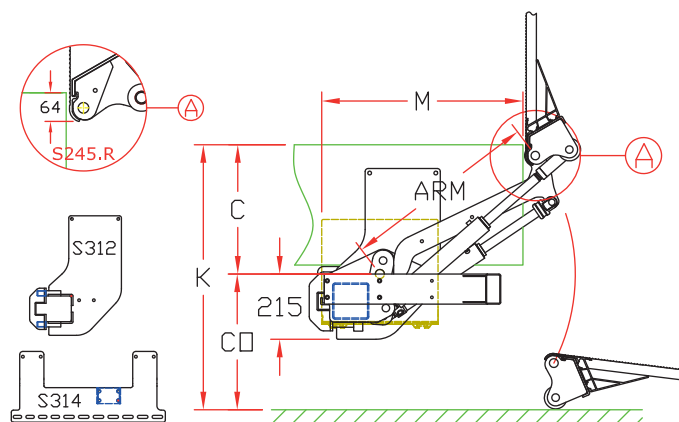

Fitting dimensions

ARM		650	750	850 (*)
K max.		1080	1220	1370
C max.		530	610	690
C min.		250	300	350
CO max.		550	610	680
M	at C max.	580	640	700
M	at C min.	770	870	950

(*) 850 mm arms optional. Consult DHOLLANDIA for the optimum solution (DH-LM.15).

Technical specifications

Lift frame	120 x 120 mm
Cylinders	2 lift cylinders + 2 tilt cylinders
Automatic tilt at ground level	Yes, mechanical
Platform material	Alu or steel (steel = 1000 kg only)
Platform overlap under floor	-64 mm
Standard platform depths	Steel: 1250-1500 mm (max. 1500) Alu: 1250-1450-1600-1800 mm (max. 2000)
Standard platform widths	Steel: 2350-2480-2500-2520-2550 mm Alu: free up to 2200 in steps of 5 mm
Lift arm lengths	650 - 750 - 850 mm
Lift arm widths	510 - 660 - 1200 mm
Standard control unit	Exterior control box with joystick, turn button safety switch, and battery isolator switch (S008.BT)